

# Eris® Series E44 / E66

High-Definition MTM Studio Monitors

高清晰度MTM有源监听音箱

Owner's Manual 用户说明

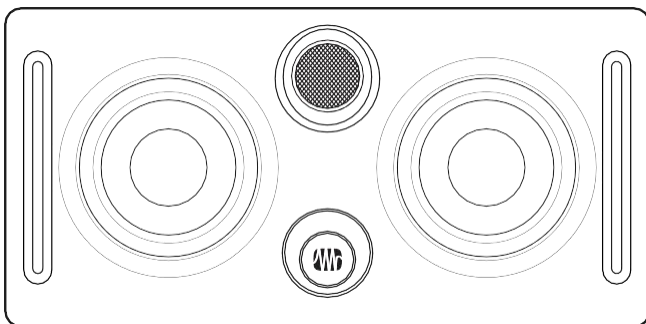
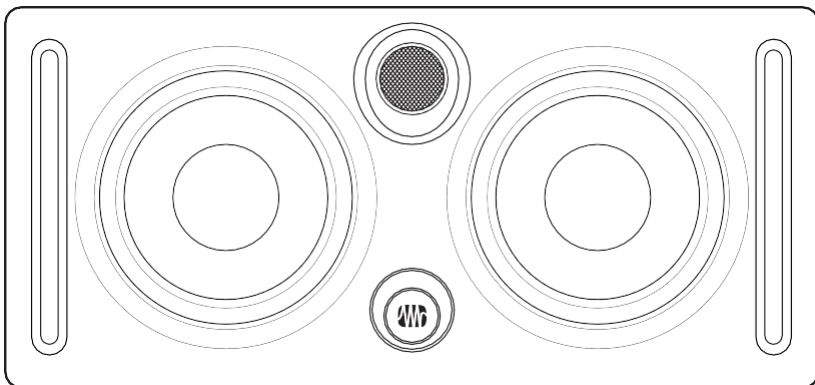

# Table of Contents 目录

## 1 Overview 概述 — 1

- 1.1 Introduction 简介 — 1
- 1.2 Summary of Eris E44/E66 Features 产品特点 — 2
- 1.3 What is in the box 产品包装内还包括什么 — 3

## 2 Hookup — 4

- 2.1 Rear Panel Connections and Controls 后面板连接和控制 — 4
  - 2.1.1 Inputs 输入 — 4
  - 2.1.2 Power 电源 — 4
    - 2.1.3 Acoustic Tuning Controls 声音调谐控制 — 5
- 2.2 Hookup Diagrams 连接图 — 6
  - 2.2.1 Basic Setup 基本设置 — 6
  - 2.2.2 Advanced Setup with Speaker Switching 用于扬声器切换的"Advanced Setup" — 7

## 3 Tutorials 教程 — 8

- 3.1 Monitor Placement 监听摆放 — 8
  - 3.1.1 Badge Rotation — 9
- 3.2 Input Gain Setting 输入增益设定 — 10
- 3.3 Equalizer Setting Suggestions 均衡器设置建议 — 10
- 3.4 Acoustic Space Setting Suggestions 声学空间设定建议 — 11

## 4 Resources 信号源 —

- 12
- 4.1 Technical Specifications 技术规格 — 12
- 4.2 Troubleshooting 故障排除 — 14

# 1 Overview 概述

## 1.1 Introduction 简介

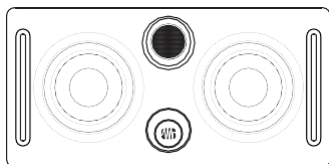
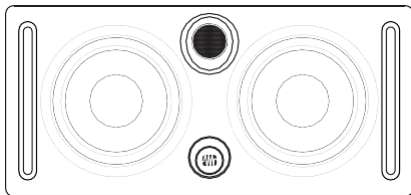

Thank you for purchasing the PreSonus Eris E44/E66 studio monitors. The E44 and E66 active monitors feature a nested MTM (midwoofer-tweeter-midwoofer) design that delivers accurate response, expanded frequency range, and the widest stereo field available in their class.

感谢你购买 PreSonus Eris E44/E66录音室监听音箱。E44和E66有源监听音箱设计特点是内装MTM（中低音扬声器-高音扬声器-中低音扬声器），提供准确的响应，扩大的频率范围，以及是同类产品中最宽的立体声场。

We encourage you to contact us at 225-216-7887 (9 a.m. to 5 p.m. Central Time) with questions or comments regarding your PreSonus Eris E44/ E66. PreSonus Audio Electronics is committed to constant product improvement, and we value your suggestions highly. We believe the best way to achieve our goal of constant product improvement is by listening to the real experts: our valued customers. We appreciate the support you have shown us through the purchase of this product and are confident that you will enjoy your Eris E44/E66!

如果对 PreSonus Eris44/Eris66 有任何疑问或是评论，我们欢迎你与我们联系，请拨打电话 225-216-7887（中部时间上午 9 时至下午 5 时）提出问题。

PreSonus Audio Electronics 致力于不断改进产品，我们非常重视你的建议。我

们坚信，产品实现不断改进产品目标的最好方法就是听取真正的专家的意见：来自我们的客户。我们感谢你通过购买该产品对我们支持，并相信，你一定会喜欢上 Eris E44/E66!

**ABOUT THIS MANUAL:** *We suggest that you use this manual to familiarize yourself with the features, applications, and correct connection procedures for your Eris E44/E66 before connecting it to the rest of your studio gear. This will help you avoid problems during installation and setup. Throughout this manual you will find **Power User Tips** that can quickly make you an Eris expert. In addition to the Power User Tips, you will find several tutorials that cover monitor placement as well as setting the Input Level, EQ, and Acoustic Space controls.*

**关于本手册：** *我们建议你将在 Eris E44/E66 连接到你的演播室设备之前，先使用本手册来熟悉它的功能、应用和正确的连接程序。这将帮助你避免在安装和设置过程中出现问题。在这本手册中，你会发现有一些 **Power User Tips** 用户提示，可以让你迅速成为 Eris 专家。除了电源用户提示外，你还会发现一些教程，包括监听音箱的放置以及设置输入电平、均衡器和声学空间的控制。*

## 1.2 Summary of Eris E44/E66 Features Eris E44/E66的特点概述

- Nested MTM design provides smooth on- and off-axis response
  - Dual 4.5/6.5" Woven composite LF Drivers produce a more dynamic output than conventional designs
  - 1.25" silk dome HF Driver
  - Supports Horizontal and Vertical speaker placement
  - LF Amplifier Power: 50W / 80W
  - HF Amplifier Power: 40W / 60W
  - Balanced XLR and ¼" TRS, and Unbalanced RCA inputs
  - Continuously Variable HF and MF Controls (-6 to +6dB)
  - Low Cut Filter (Flat, 80Hz, 100Hz)
  - Acoustic Space settings (Flat, -2 dB, -4 dB) compensates for room placement
  - RF interference, Output-current Limiting, Over-temperature, and Subsonic filter protection
  - External mains fuse
  - Power: 110-120V ~50/60 Hz or 220-240V ~50/60 Hz
- 
- 内装MTM设计，提供平滑的轴上和轴下响应
  - 4.5/6.5 "编织复合低频驱动器制造比传统设计更多的动态输出
  - 1.25 "丝质圆顶高频驱动器
  - 水平支撑和垂直放置扬声器
  - LF低频放大器功率：50W / 80W
  - HF高频放大器功率：40W / 60W
  - XLR和¼"TRS 平衡输入，以及RCA不平衡R输入
  - 连续可变的高频和中频控制（-6至+6dB）。
  - 低切滤波器（平坦，80Hz，100Hz）。
  - 声学空间设置（平坦，-2分贝，-4分贝）可补偿房间的位置
  - 射频干扰、输出电流限制、过热和亚音速滤波器保护
  - 外部电源保险丝
  - 电源：110-120V ~50/60 Hz或220-240V ~50/60 Hz



## 1.3 What is in the box 产品包装内还包括什么

In addition to this manual, your Eris E44/  
E66 package contains the following:

除本手册外，你的 Eris E44/ E66 包  
装内还包括以下内容：

- (1) PreSonus Eris E44 or E66 powered studio monitor
- (1个) PreSonus Eris E44或E66 录音室有源监听音箱

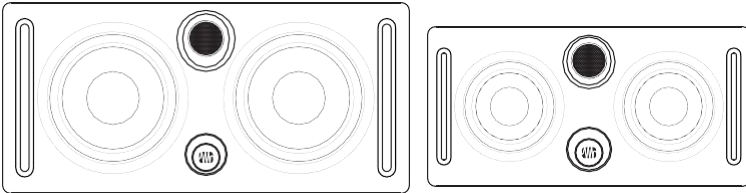

- (1) IEC power cable

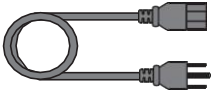

- (1个) IEC电源线



- (6) Foam feet to be placed on the bottom of the speaker to improve isolation
- (6个) 放在音箱底部的泡沫橡胶垫，以提高隔离度

## 2 Hookup 联机

### 2.1 Rear Panel Connections and Controls 后面板连接和控制

#### 2.1.1 Inputs 输入

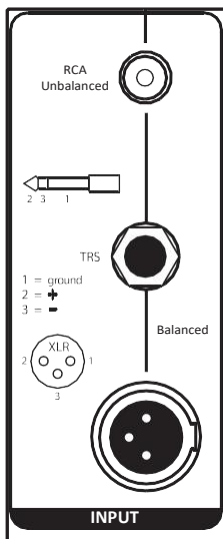

**Line-level Inputs.** The Eris E44/E66 provides a choice of three inputs: two balanced (XLR and 1/4" TRS) and one unbalanced (RCA). These inputs accept a line-level signal from your audio source and feed that signal to the monitor's built-in power amplifiers. These inputs are provided to allow for flexible connectivity and not for connecting multiple sources to your speakers simultaneously. **Please connect only one source to your Eris E44/E66.**



**线路水平输入。** Eris E44/E66提供三种输入选择：两个平衡（XLR和1/4"TRS）和一个非平衡（RCA）。这些输入接受来自音源的线级信号，并将该信号送入显示器的内置功率放大器。提供这些输入是为了实现灵活的连接，而不是为了将多个音源同时连接到你的扬声器。请仅连接一个音源到你的 Eris E44/E66。

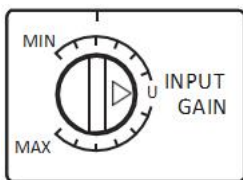

**Power User Tip:** If your audio source provides balanced XLR or 1/4" TRS (tip-ring-sleeve) outputs, use one of the corresponding balanced Eris inputs, since balanced cables are resistant

to induced noise from radio-frequency or electromagnetic interference (RFI or EMI). If the audio source has unbalanced 1/4" TS (tip-sleeve) outputs, use a 1/4"-to-RCA adapter or adapter cable. Always use the shortest cable possible to minimize the risk of induced RFI or EMI noise.

**Input Gain:** Sets the level of the input signal before it is amplified.

**用户提示：** 如果你的音源提供平衡 XLR 或 1/4" TRS（平衡



线) 输出, 请使用相应的平衡 Eris 输入, 因为平衡电缆可以抵抗射频或电磁干扰 (RFI或EMI) 所引起的噪音。如果音源有不平衡的 $\frac{1}{4}$ " TS (非平衡) 输出, 请使用 $\frac{1}{4}$ "-RCA适配器或转接电缆。始终使用短的电缆, 以尽量减少RFI或EMI的噪音的风险。

### 2.1.2 Power 电源



**IEC Power Connection:** Your Eris E44/E66 accepts a standard IEC power cord.

**Warning:** Do not remove the center grounding prong or use a ground-lift adapter, as this could result in electric shock.

**IEC电源连接:** 你的 Eris E44/E66 可接受标准的 IEC 电源线。

**警告:** 不要拔掉中间的接地线或使用接地线适配器, 因为这可能导致电击。

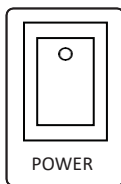

**Power Switch.** This is the On/Off switch. The power status is indicated by an LED on the front of the cabinet.

**电源开关。**这是一个开/关键。电源状态由机壳前面的LED灯显示。

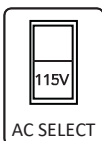

**AC Select Switch.** The input-power voltage is set at the factory to correspond with the country in which it was shipped. Use this switch only if you are using your Eris speakers in a country that uses a different standard voltage than is used in the country where you purchased your Eris E44 or E66.

**AC选择开关。**输入电源电压在出厂时就已经设置好了，与出厂时的国家一致。只有当你 Eris扬声器的使用地与你的购买地不同的标准电压时，才能使用此开关。

### 2.1.3 Acoustic Tuning Controls 声学调谐控制

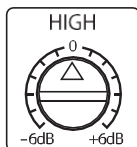

**High:** Boosts or cuts all frequencies above 10 kHz by  $\pm 6$  dB.

**高：**将10kHz以上的所有频率提升或削减 $\pm 6$ dB。

**Power User Tip:** The High control on the Eris E44/E66 is a high-shelf EQ and attenuates or boosts frequencies above 10 kHz. This EQ is much like the treble control on a car stereo: It raises or lowers the gain on all frequencies above the specified cutoff frequency. Shelving EQs can make big changes to the sound very quickly by adding or removing an entire range of frequencies.

**用户提示：**Eris E44/E66 的 "High" 控制是一个高阶均衡器，可以衰减或提升10kHz以上的频率。10kHz以上的频率。这个EQ很像汽车音响上的高音控制。它提高或降低指定截止频率以上的所有频率的增益。搁架式均衡器通过增加或删除整个频率范围，可以迅速对声音做出关键改变。

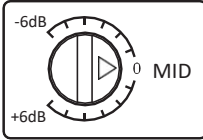

**Mid:** Boosts or cuts frequencies around 1 kHz by  $\pm 6$  dB. The Mid control is a peak EQ that lets you boost or cut a specified frequency band (in this case, a band about two octaves wide, centered at 1 kHz). It's capable of more subtle changes.

**Mid:** 将1kHz附近的频率提升或削减 $\pm 6$ dB。中音控制是一个峰值均衡器，让你提升或削减一个指定的频段（在这个例子中，一个大约两个八度的宽频段，以1kHz为中心）。它能够实现更微妙的变化。

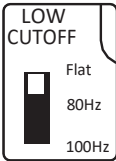

**Low Cutoff:** Rolls off the level of all frequencies below the specified frequency (80 or 100 Hz) at a slope of -12 dB/octave. Can be defeated by setting it to Flat, in which case, the monitor's natural rolloff takes over.

**Low Cutoff:** 以 -12dB/倍频程的斜率滚落低于指定频率（80或100Hz）的所有频率的电平。可以把它设置为Flat（平直），在这种情况下，显示器 natural（自然）滚降会被取代。

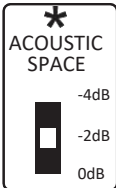

**Acoustic Space:** Cuts the level of all frequencies below 800 Hz by the specified amount (-2 or -4 dB) to compensate for the bass boost that occurs when the monitor is placed near a wall or corner. Can be defeated by setting it to 0 dB.

**Acoustic Space:** 将800赫兹以下的所有频率的电平按指定的量（-2或-4分贝）削减，当监听器被放置在墙或角落附近时，以补偿发生的低音增强现象。可以通过将其设置为0分贝的方式来解决。

## 2.2 Hookup Diagrams 连接图

### 2.2.1 Basic Setup 基本设置

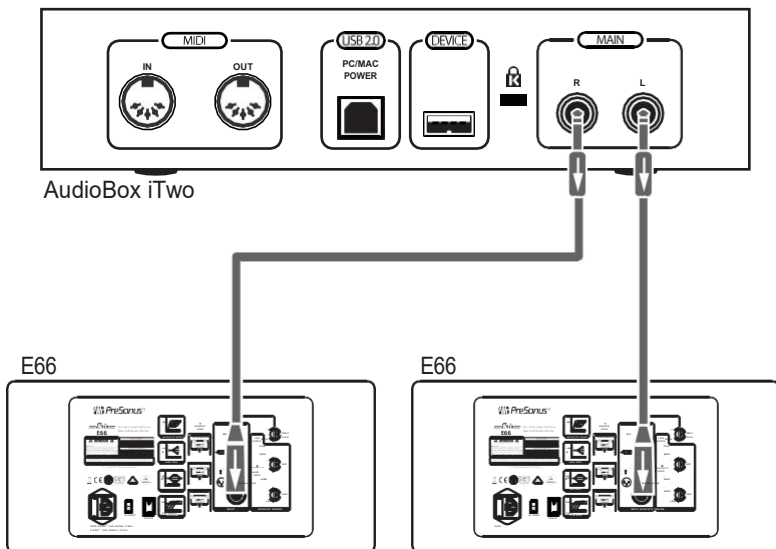

### 2.2.2 Advanced Setup with Speaker Switching 用于扬声器切换的 "Advanced Setup"

Studio 192

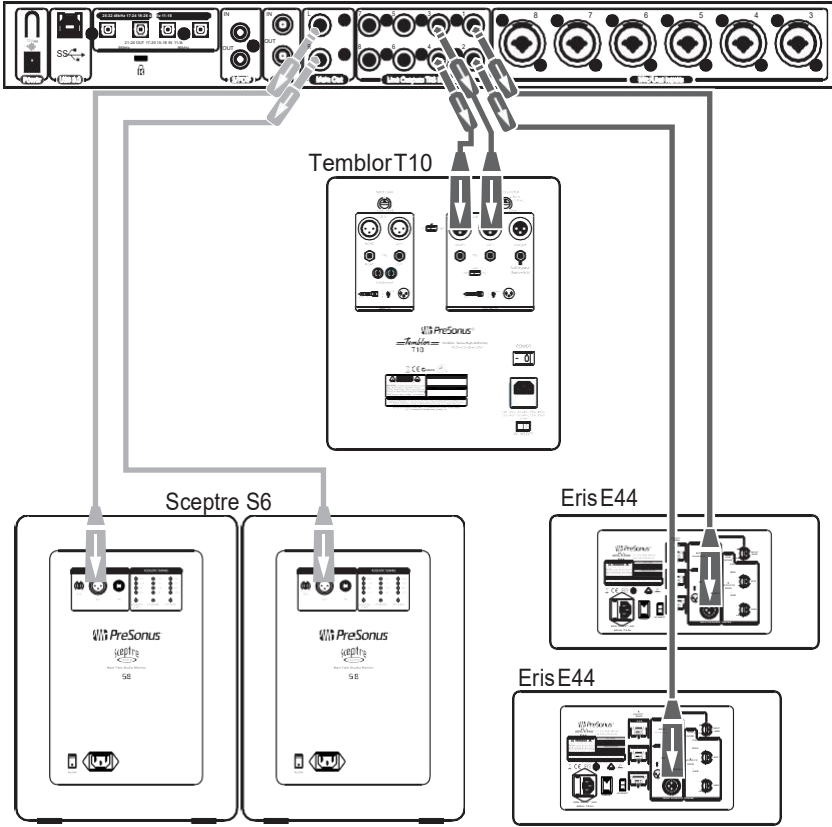

## 3 Tutorials 教程

### 3.1 Monitor Placement 监听放置

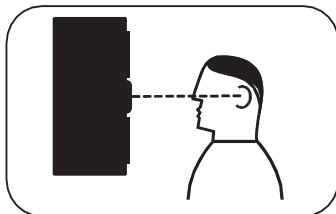

Ideally, near-field monitors should be placed so that the tweeters are at the same height as your ears when you are mixing.

理想情况下，近场监听音箱的摆放位置应该是：当你混音时，高音扬声器与你的耳朵处于同一高度。

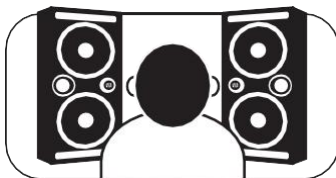

Eris E44 and E66 speakers can be placed vertically or horizontally; when placed vertically, they should form a mirror-image pair, with the tweeters on the outside.

Eris E44和E66扬声器可以垂直或水平放置；垂直放置时，它们应形成一对镜像，高音扬声器在外面。

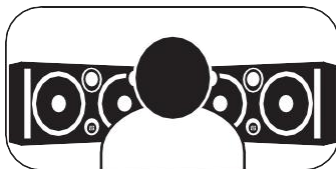

When placed horizontally, the tweeters should be on top.

当水平放置时，高音扬声器应在上面。

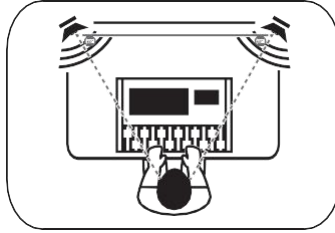

The speakers should be separated so that the tweeters form an equilateral triangle with your head. The monitors should be “toed in,” or angled, so that they are pointed at you, not pointed straight ahead.

扬声器应该分开，使高音扬声器与你的头部形成一个等边三角形。监听设备应该形成“内八字”，或有一定的角度，以便它们指向你，而不是直指前方。

### 3.1.1 Badge Rotation

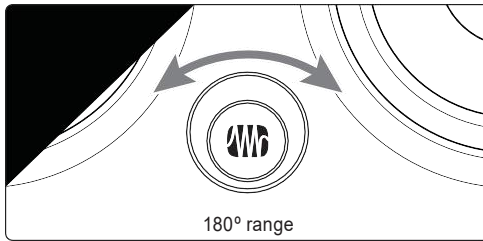

The logobadge on your Eris E44 and E66 can rotated to match their orientation in your studio. Once you have positioned your monitors in the orientation that works the best for you, simply use your fingers to twist the logo so that it is right side up.

你的 Eris E44 和 E66 的Logo标记可以转动，以配合他们在你工作室的方向一致。一旦你将监听器放置在最适合你的方向，只需用你的手指扭动Logo标记，使其右侧朝上。

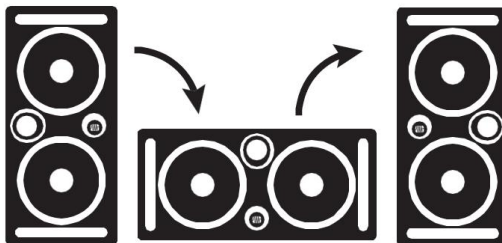

## 3.2 Input Gain Setting 输入增益设定

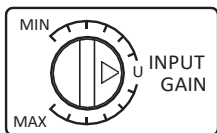

The best place to start is to set the Input Level control at its unity gain position (labeled "U"). That means the level of the signal reaching the amplifier is the same as the level of the signal entering the monitor's input. This ensures a good, strong signal level without amplifying any extraneous noise. Make sure that the gain controls on your audio source have been optimized for maximum signal level and minimum noise. This process is called "gain staging," and you can learn about it from many online sources. You should always set the Input Gain on your Eris monitor so that all other level controls in the system needn't be turned way up or way down to achieve a comfortable listening volume.

最好的开始是将输入电平控制设置在统一增益的位置（标有"U"）。这意味着到达放大器的信号电平与进入监听输入的信号电平相同。这样保证一个良好的、强大的信号电平，任何无关的噪音不会放大。确保音源上的增益控制已经被优化为最大的信号电平和最小的噪音。这个过程被称为"增益分期"，你可以从许多在线资料中了解到这一点。你应该一直设置Eris监听音箱的输入增益，以便系统中的所有其他电平控制不需要调得很高或很低来达到舒适的聆听音量。

If setting the input gain to Unity is unsatisfactory, you can try different settings, but remember that it's better to avoid settings above U if possible. If the volume is too loud at unity gain, feel free to turn the Input Gain control down a bit—but not so far that you have to crank your audio source's output level to its maximum setting. If you set it too low, you'll have to crank your audio source's output level way up, which will increase the audible noise from your source signal. If you set it too high, any noise in the signal will be amplified, which you don't want, either! Again, if you properly gain-stage your audio source, setting Input Gain to U or slightly lower should work fine.

Once the monitor's Input Gain control is set, leave it alone; don't use it as a system-volume control. Leave that job to your audio device's output-level control.

如果不满意输入增益设置为 Unity，你可以尝试不同的设置，但要记住，如果可能的话，最好避免设置在U以上。如果在统一增益下音量过大，可以随时将输入增益控制调低一点，但又不至于要把音源输出电平调到最大设置。如果把它设置的太低，你不得不把你的音源输出电平拉高，这将增加你的源信号的 audible 噪声。如果你设置得太高，信号中的任何噪音都会被放大，这也是你不希望看到的。同



样，如果你对你的音源进行了适当的增益分级，将输入增益设置为0或略低，应该可以正常工作。

一旦监听器的输入增益控制设置好了，就不要再管它了；不要把它作为系统音量控制。把这项工作留给你的音频设备的输出电平控制。

### 3.3 Equalizer Setting Suggestions 均衡器设置建议

The Eris E44/E66 provides three EQ controls in its Acoustic Tuning section: High, Mid, and Low Cutoff. (There's also an Acoustic Space control, which is covered in the next section.) In general, setting the High control to 0 (no boost or cut) will produce the best results. However, if the sound is generally too bright or shrill, try turning this control down below 0; if the sound is too dull and lifeless, try turning it up above 0. It's always better to cut than to boost and to use the smallest cut or boost needed to get the job done.

The Mid control is a mid-frequency peak filter that boosts or cuts frequencies centered on 1 kHz and extending about one octave above and below that frequency. Again, setting this control to 0 will generally produce the best results. If you want to emulate a car stereo, try turning it down below 0 to approximate the common "smiley face" EQ curve. On the other hand, if you want to emulate a cheap portable radio, try turning it up above 0. Try not to boost much, since this can add noise to the signal.

Eris E44/E66 在其声学调谐部分提供了三个EQ控制：“High, Mid, and Low Cutoff”。(还有一个声学空间控制，这将在下一节介绍)。一般来说，将高音控制设置为0（没有提升或削减）会产生最好的效果。但是，如果声音通常太亮或太尖，可以试着把这个控制调到0以下；如果声音太沉闷，不生动，可以试着把它调到0以上。削减总是比提升好，使用最小的削减或提升来完成工作。

Mid 控制是一个中频峰值滤波器，它可以提升或削减以1kHz为中心的频率，并在该频率上下延伸约一个八度。同样，将这个控制设置为0一般会产生最好的效果。如果你想模拟汽车音响，可以试着把它调到0以下，以接近常见的 "smiley face" EQ 插件。另一方面，如果你想模拟一个简单的便携式收音机，试着把它调到0以上。

The Low Cutoff control rolls off the low frequencies below the specified frequency (80 or 100 Hz). Engage this control if you are using a subwoofer in conjunction with the Eris E44/E66 monitors, and set it to the same frequency as the crossover to the subwoofer. If you're not using a subwoofer, set the control to Flat. If you want to emulate a cheap radio, engage this control at 80 or 100 Hz while boosting the Mid control.

Low Cutoff 控制可以减弱低于指定频率（80或100赫兹）的低频。如果你在使用Eris E44/E66监听音箱的同时使用一个超重低音扬声器，请启用该控制，并将其设置为与超重低音扬声器的分频器相同的频率。如果你不使用超重低音扬声器，将该控制设置为Flat（平直）。如果你想模仿简单的收音机，把这个控制设置为80或100赫兹，同时提高Mid控制。

**Power User Tip:** Do not use the EQ controls on your Eris monitor to correct problems in your mix. While this changes what you hear in the control room, it has no effect on your recorded audio.

**用户提示：** 不要使用 Eris 监听音箱上的 EQ 控制来纠正混音中的问题。虽然这改变了你在控制室里听到的东西，但对你录制的音频没有影响。

### 3.4 Acoustic Space Setting Suggestions 声学空间设置建议

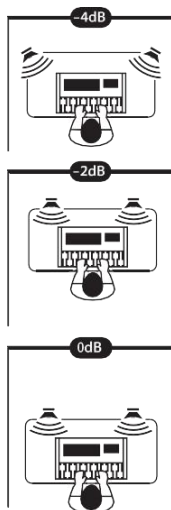

When a monitor is placed close to a wall, or in a corner, the low frequencies tend to be emphasized more than if the monitor is far from any room boundary; this effect is called "boundary bass boost." It is most pronounced if the monitor is in a corner and less pronounced, but present, if the monitor is near one wall.

当监听器被放置靠近墙壁或角落时，低频比监听器远离任何房间边界时，更加突出；这种效果被称为“边界低音增强”。如果监听器在一个角落里，则最为明显；如果监听器靠近一面墙，则不太明显，但也存在。

To compensate for this bass boost, the Eris E44/E66 provides an Acoustic Space switch that cuts all frequencies below 800 Hz by a fixed amount.

为了补偿这种低音增强，Eris E44/E66 提供了一个声学空间开关，将800赫兹以下的所有频率削减一个固定数额。

If the monitors are close to the corners of the room, start by setting the Acoustic Space switch to -4 dB, which provides the most bass attenuation.

如果监听器靠近房间的角落，首先将声学空间开关设置为-4dB，这样可以提供最大的低音衰减。

If the monitors are close to the back wall, try setting the Acoustic Space switch to -2 dB for less attenuation.

如果监听器离后墙很近，可以尝试将声学空间开关设置为-2dB，以减少衰减。

If the monitors are far from any wall, there will be no bass boost, so set the switch to 0 dB.

如果监听器离任何墙都很远，就不会有低音提升，所以要把开关设为 0dB。

## 4 Resources 信号源

### 4.1 Technical Specifications 技术规格

#### INPUTS 输入 (E44 and E66)

1- Balanced XLR

1- Balanced ¼" TRS

1- Unbalanced RCA

#### PERFORMANCE 性能

##### Frequency Response 频率响应

E44 55 Hz to 22 kHz

E66 45 Hz to 22 kHz

##### Crossover Frequency 分频器频率

E44 2.9 kHz

E66 2.4 kHz

##### LF Amplifier Power 低频放大器功率

E44 50W

E66 80W

##### HF Amplifier Power 高频放大器功率

E44 35W

E66 65W

##### Peak SPL at 1M 1M时的峰值声压级

E44 103 dB

E66 106 dB

##### LF Drivers 低频驱动器

E44 dual 4.5" Woven composite

E66 dual 6.5" Woven composite

##### HF Driver 高频驱动器

E44 1.25" silk dome

E66 1.25" silk dome

## Input Impedance 输入阻抗

E44 and E66 10 kΩ

---

## USER CONTROLS 用户控制

---

### Volume Range 音量范围

E44 and E66 A-type taper

---

### MF Control 中频控制

E44 and E66 Variable (-6 to +6 dB)

---

### HF Control 高频控制

E44 and E66 Variable (-6 to +6 dB)

---

### Low Cut

E44 and E66 Flat, 80 Hz, 100 Hz

---

### Acoustic Space 声学空间

E44 and E66 Flat, -2 dB, -4 dB

---

## PROTECTION (E44 and E66) 保护

---

RF interference 射频干扰

Output-current limiting 输出电流限制

Over-temperature 过热

Turn-on/off transient 瞬态开启/关闭

Subsonic filter 亚音速滤波器

External mains fuse 外部电源保险丝

---

## POWER 电源

---

E44 and E66 100-120V ~50/60 Hz or 220-240V ~50/60 Hz

---

## CABINET 机壳

---

E44 and E66 Vinyl-laminated MDF  
乙烯基夹层中密度纤维板

---

## PHYSICAL 物理

---

(Width宽/Height高/Depth深)

E44	7"x7"x14.3"(180mmx180mmx365mm)
E66	8.5"x9.8"x18.1"(215mmx250mmx460mm)

**Weight 重量**

E44	11.9lb(5.4kg)
E66	23.4lb(10.6kg)



## 4.2 Troubleshooting 故障排除

**No Power.** First ensure that your Eris E44/E66 is plugged in. If it's connected to a power conditioner, verify that the power conditioner is turned on and functioning.

**No Power.** 首先确保你的 Eris E44/E66 已经将插头插上。如果它连接到一个电源调节器上，请确认电源调节器已打开并是正常工作。

If problem still exists, disconnect the power cable from your E44/E66 and check the fuse on the back panel of your E44/ E66. The fuse housing is located directly beneath the IEC power cable connection. A blown fuse may look black on the inside or the wire inside might appear broken. A very black fuse is a sign that something may have shorted out. Try replacing the fuse with a new one. The type of fuse needed for your monitor is listed below the power inlet. Be sure to use the correct fuse for the set input-power voltage. If the fuse blows again, you will need to contact PreSonus for a repair.

如果问题仍然存在，请断开 E44/E66 的电源线，检查 E44/E66 背板上的保险丝。保险丝外壳位于 IEC 电源线连接处的正下方。熔断的保险丝内部可能看起来是黑色的，或者内部的电线可能出现断裂。保险丝非常黑，说明可能有东西短路了。请尝试用一个新的保险丝替换。您的监听器所需的保险丝类型列在电源入口的下面。请确保为设定的输入电源电压，使用正确的保险丝。如果保险丝再次熔断，你需要联系 PreSonus 进行维修。

**No audio.** If your Eris E44/E66 appears to power on but you hear no sound when playing audio from your audio source (the lights are on but nobody's home), first make sure that the cable connecting your audio source to the monitor is working correctly. Also, verify that the Input Gain control is set to provide enough amplitude for the signal.

**No audio.** 如果你的 Eris E44/E66 出现开机现象，但在播放音源的音频时，没有听到声音（灯亮了，却无人在家），首先要确认连接音源和监听器的电缆是否是正常工作。另外，输入增益控制的设置是否为信号提供足够的振幅。

**Hum.** Usually, hum is caused by a ground loop. Verify that all audio equipment is connected to the same power source. If you are not using a power conditioner, we highly recommend that you add one. Not only will



this help to minimize hum, it will better protect your equipment from power surges, brownouts, etc.

Use balanced cables whenever possible. If your audio device does not offer a balanced output, you can connect it to a direct box, which will provide a ground-lift switch and a balanced output.

**Hum.** 通常情况下，嗡嗡声是由接地回路引起的。确认所有的音频设备都连接到同一个电源上。如果你没有使用电源调节器，我们强烈推荐，要添加一个。这不仅有助于最大限度地减少嗡嗡声，而且可以更好地保护你的设备免受电压浪涌、断电等影响。

尽可能地使用平衡电缆。如果你的音频设备不提供平衡输出，你可以把它连接到一个直连箱，这将提供一个接地开关和一个平衡输出。

Finally, make sure that your audio cables are not run near power cables, and use cables that are the appropriate length for your application. Using cables that are too long not only increases the risk of noise, it increases the likelihood that the cables are coiled, which will essentially create an antenna that picks up all kinds of audio interference.

最后，确保你的音频电缆不靠近电源线，并使用适合你的应用长度的电缆。使用太长的电缆不仅会增加噪音的风险，还会增加电缆盘绕的可能性，大体上会形成一个天线，接收各种音频干扰。

## Added bonus: PreSonus' previously Top Secret recipe for... Rice Dressing

### 额外的奖励：PreSonus以前的绝密配方... 米饭调味酱

#### Ingredients 成分:

- 1lb ground beef
- 1 lb chopped chicken liver
- 1 onion (diced)
- 2 green peppers (diced)
- 4-6 celery stalks (diced)
- 2 garlic cloves (minced)
- ¼ C. chopped fresh parsley
- 3 C. chicken stock
- 6 C. cooked rice
- 1 Tbs. oil
- Salt and pepper to taste
- Cayenne pepper to taste

- 1磅碎牛肉
- 1磅切碎的鸡肝
- 1个洋葱（切丁）
- 2个青椒（切丁）
- 4-6根芹菜茎（切丁）
- 2个大蒜瓣（切碎）
- ¼ C. 切碎的新鲜欧芹
- 3 C. 鸡汤
- 6 C. 煮熟的米饭
- 1汤匙油
- 盐和胡椒粉调味
- 辣椒适量

## Cooking Instructions:

### 烹饪指导:

1. In a large pot, heat oil on medium high and add meat, salt, and pepper to taste. Stir until meat begins to brown.
2. Lower heat and add all vegetables. Cook until onions are transparent and celery is very tender. Add stock as necessary to prevent burning.
3. Stir in cooked rice. Add remaining stock and simmer on low until ready to serve.

1. 在一个大锅中，加热油，调到中高火，加入肉、盐和胡椒粉调味。搅拌直到肉开始变色。

2. 降低火力，加入所有蔬菜。煮至洋葱透明，芹菜非常柔软。必要时加入高汤以防止烧焦。

3. 加入煮好的米饭搅拌。加入剩余的汤汁，小火慢炖，直到可以食用。

# Eris® Series E44 / E66

## High-Definition MTM Studio Monitors

### 高清晰度MTM有源监听音箱

### Owner's Manual 用户手册

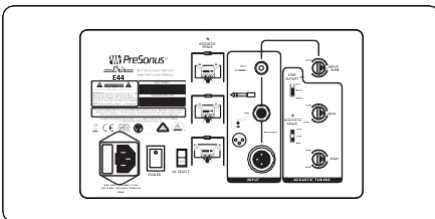
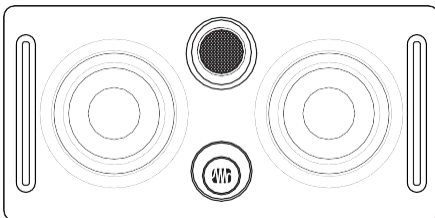
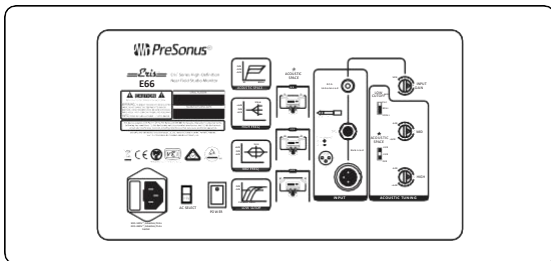
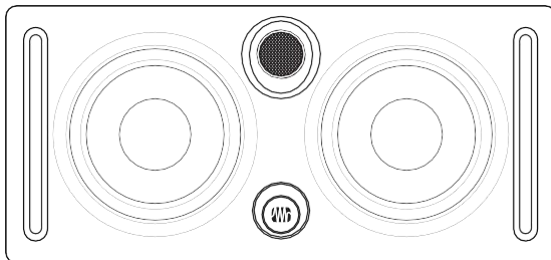

Baton Rouge • USA

[www.presonus.com](http://www.presonus.com)

Part# 75-50500040-C