

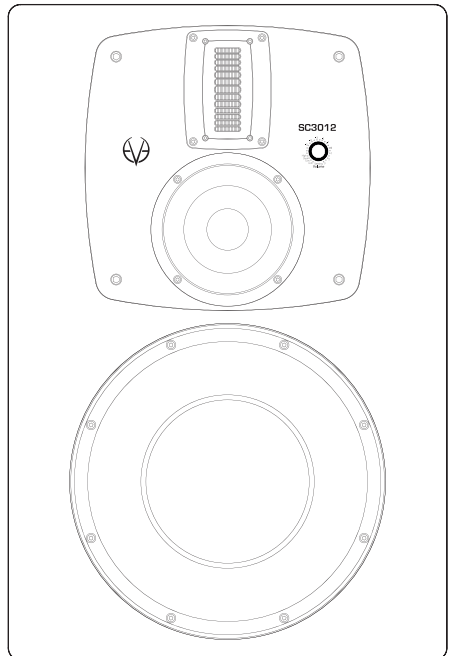

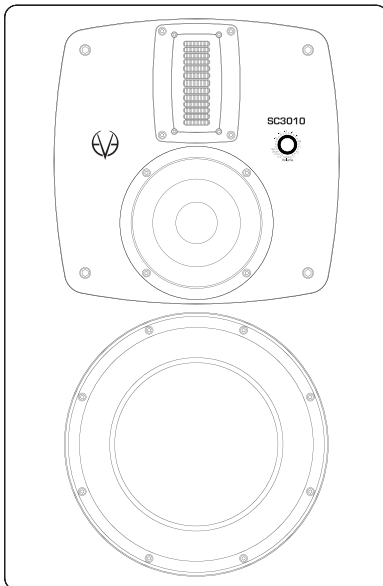



eve audio

**SC3010**  
**SC3012**



## **SAFETY INSTRUCTIONS**

1. READ these instructions.
2. KEEP these instructions.
3. HEED all warnings.
4. FOLLOW all instructions.
5. DO NOT use this apparatus near water.
6. CLEAN ONLY with dry cloth.
7. DO NOT block any ventilation openings. Install in accordance with the manufacturer's instructions.
8. DO NOT install near any heat sources such as radiators, heat registers, stoves, or other apparatus (including amplifiers) that produce heat.
9. DO NOT defeat the safety purpose of the polarized or grounding-type plug. A polarized plug has two blades with one wider than the other. A grounding type plug has two blades and a third grounding prong. The wider blade or the third prong are provided for your safety. If the provided plug does not fit into your outlet, consult an electrician for replacement of the obsolete outlet.
10. PROTECT the power cord from being walked on or pinched particularly at plugs, convenience receptacles, and the point where they exit from the apparatus.
11. ONLY USE attachments/accessories specified by the manufacturer.
12. USE ONLY with the cart, stand, tripod, bracket, or table specified by the manufacturer, or sold with the apparatus. When a cart is used, use caution when moving the cart/apparatus combination to avoid injury from tip-over.
13. UNPLUG this apparatus during lightning storms or when unused for long periods of time.
14. REFER all servicing to qualified service personnel. Servicing is required when the apparatus has been damaged in any way, such as power-supply cord or plug is damaged, liquid has been spilled or objects have fallen into the apparatus, the apparatus has been exposed to rain or moisture, does not operate normally, or has been dropped.

15. To reduce the risk of fire or electric shock, do not expose this apparatus to rain or moisture. The apparatus shall not be exposed to dripping or splashing and that objects filled with liquids, such as vases, shall not be placed on apparatus.
16. Where the MAINS plug or an appliance coupler is used as the disconnect device, the disconnect device shall remain readily operable.
17. DO NOT overload wall outlets or extension cords beyond their rated capacity as this can cause electric shock or fire.
18. No naked flame sources, such as lighted candles, should be placed on the apparatus.
19. Minimum distances around the apparatus for sufficient ventilation.
20. The ventilation should not be impeded by covering the ventilation openings with items, such as newspapers, table cloths, curtains, etc.
21.  Correct Disposal of this product. This marking indicates that this product should not be disposed with other household wastes throughout the EU. To prevent possible harm to the environment or human health from uncontrolled waste disposal, recycle it responsibly to promote the sustainable reuse of material resources. To return your used device, please use the return and collection systems or contact the retailer where the product was purchased. They can take this product for environmental safe recycling.
22.  The lightning flash with arrowhead symbol within an equilateral triangle is intended to alert the user to the presence of uninsulated "dangerous voltage" within the product's enclosure that may be of sufficient magnitude to constitute a risk of electrical shock to persons.
23.  The exclamation point, within an equilateral triangle, is intended to alert the user to the presence of important operating and maintenance (servicing) instructions in the literature accompanying the product.
24.  **WARNING: Do Not Open! Risk of Electrical Shock. Voltages in this equipment are hazardous to life. No user-serviceable parts inside. Refer all servicing to qualified service personnel. Place the equipment near a main power supply outlet and make sure that you can easily access the power breaker switch.**

# SC3010 SC3012

---

25. **WARNING:** This product is intended to be operated **ONLY** from the AC Voltages listed on the back panel or included power supply of the product. Operation from other voltages other than those indicated may cause irreversible damage to the product and void the products warranty. The use of AC Plug Adapters is cautioned because it can allow the product to be plugged into voltages in which the product was not designed to operate. If the product is equipped with a detachable power cord, use only the type provided with your product or by your local distributor and/or retailer. If you are unsure of the correct operational voltage, please contact your local distributor and/or retailer.

## TABLE OF CONTENTS

<b>1.</b>	<b>INTRODUCTION .....</b>	<b>6</b>
<b>2.</b>	<b>QUICK START .....</b>	<b>7</b>
2.1.	First Steps .....	7
2.2.	Speaker Connection .....	7
2.3.	Powering On .....	7
<b>3.</b>	<b>OPERATION .....</b>	<b>8</b>
3.1.	First Steps .....	8
3.2.	Horizontal/Vertical Orientation .....	8
3.3.	Operating Modes .....	9
3.4.	Powering on/off: Standby Mode .....	10
3.5.	Volume Mode .....	10
3.6.	Settings Menu .....	11
3.7.	Filters .....	12
3.8.	Low Filter .....	12
3.9.	High Filter .....	12
3.10.	Mid Filter .....	13
3.11.	Desk Filter .....	13
3.12.	LED Mode .....	14
3.13.	Saving Your Settings .....	15
3.14.	Power Switch .....	15
3.15.	DIP Switches .....	15
3.16.	Mains Voltage Selector .....	16
3.17.	Power Connector (IEC) .....	16
<b>4.</b>	<b>POSITIONING .....</b>	<b>16</b>
4.1.	Speaker Positioning + Rubber Feet .....	16
4.2.	Height and Distance .....	17
4.3.	Stereo Setup .....	18
4.4.	Mixer/Workplace Reflections .....	18
4.5.	Room Acoustics .....	20
<b>5.</b>	<b>TECHNICAL SPECIFICATIONS .....</b>	<b>21</b>
<b>6.</b>	<b>COMPLIANCE .....</b>	<b>22</b>
<b>7.</b>	<b>WARRANTY .....</b>	<b>23</b>

## 1. INTRODUCTION

Thank you for your time and interest in the EVE Audio product range.

EVE Audio is a loudspeaker manufacturer based in Berlin, Germany, that specializes in the development and design of unique studio monitors.

The use of first-class components is our highest priority because we firmly believe this is the only way to manufacture first-class products.

You have chosen a loudspeaker from our Silvercone SC series. Both models — SC3010 and SC3012 — were conceived as main monitor systems.

Both models are equipped with a long-excursion bass woofer with hexagonal glass fibre layered diaphragm providing an extraordinarily clean low frequency reproduction, even at higher than usual SPL's. Our newly developed 5" midrange driver with glass fibre layered Rohacel™ sandwich diaphragm ensures a clear and detailed midrange frequency reproduction. Both SilverCone drivers are equipped with our very low distortion copper cap magnet system.

Especially developed for our main monitors, the Air Motion Transformer AMT RS6 is 2.5 times bigger than the RS1, RS2 and RS3 units, and it is a crucial part of the system as it helps to couple the middle and high frequencies with great precision. Our team was able to engineer the RS6 to set its crossover frequency at 1800 Hz, a very important frequency for human hearing and subsequently, music production.

Each driver is powered by its own custom PWM amplifier. Tweeter and midrange are supported with a 250W amplifier each while the bass woofer is amplified with a bridged 800W PWM module. All drivers are protected with a limiter detection circuit. The system is controlled by a high-resolution DSP.

We wish you a lot of fun with your EVE Audio monitors. If you have any questions regarding our products, do not hesitate to contact your nearest dealer or get directly in touch with us... We will be more than happy to help you out!

All the best from Berlin.

The EVE Audio Team

## 2. QUICK START

If you already have experience with studio monitors, the Quick Start guide ought to be more than enough to get you started.

For unexperienced users we recommend reading the whole user's manual in order to prevent any misuse.

### 2.1. First Steps

Check the package components (loudspeaker, user's manual, power cord, rubber feet).

Check the voltage setting (see "3.16. Mains Voltage Selector" on page 16).

Check the setting of the DIP Switches (variable).

### 2.2. Speaker Connection

Connect one of the monitor inputs on the rear side (RCA or XLR) to the line output of a playback source, for instance, an audio interface. The output level should be as low as possible.

### 2.3. Powering On

Engage the Power switch on the rear side of the loudspeaker to turn it on or off.

The LEDs around the Volume control on the front panel will light up clockwise. If the LED on the right end is dimly lit, this indicates that the loudspeaker is in Standby mode. Press the Volume control to turn the loudspeaker on. If you turn the Volume control counter clockwise until the LED on the left end lights up dimly the loudspeaker will be muted.

Increase the output level on the source device until the LED ring starts to blink, then reduce the output level a bit. The maximum operating level for the input (i.e. the analog to digital converter) is now set optimally. To set the desired listening volume use the Volume control on the loudspeaker. The LED ring indicates the volume setting. If the LED ring starts to blink, reduce the output level on the signal source.

## 3. OPERATION

### 3.1. First Steps

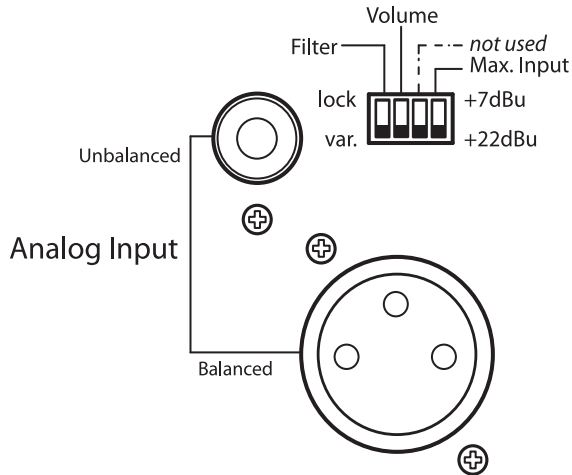

*Rear Connections & DIP Switches*

Check the package components (loudspeaker, user's manual, power cord, rubber feet);

Check the voltage setting ("3.16. Mains Voltage Selector" on page 16).

Check the setting of the DIP Switches (variable).

Connections: there are two input connectors on the rear side. These allow the connection of balanced sources with XLR connectors or unbalanced sources with RCA connectors.

- Pin assignment XLR: 1 = Shield, 2 = hot (+), 3 = cold(-).
- Pin assignment RCA: Center conductor = Signal, Ring = Shield.

Both analog inputs can be used simultaneously, whereby the signals are summed.

Depending on the setting of the Max. Input DIP switch on the rear panel, the maximum level of the source signal should not exceed +7 dBu or +22 dBu (see "3.15. DIP Switches" on page 15, Max. Input). If the input is overloaded the LED ring will start blinking.

### 3.2. Horizontal/Vertical Orientation

The SC3010 and SC3012 can be used in horizontal or vertical position



thanks to the incorporated swiveling „Mid/High Silver Plate.“ By default, your monitor is adjusted to be placed vertically. To use it in horizontal position, turn the tweeter/mid-driver section 90° so that the sound transducer is still vertically oriented. Your dealer will be happy to do this for you. If you would like to do it by yourself after the monitors have been installed, follow these steps:

- Remove the four screws of the mid/high plate.
- Turn the whole tweeter/mid-driver section 90°. The direction does not really matter. Hold the tweeter/mid-driver section by the screws when handling it.
- Fasten the tweeter/mid-driver section again with the screws. Tighten the screws only a bit tighter than you would by hand.

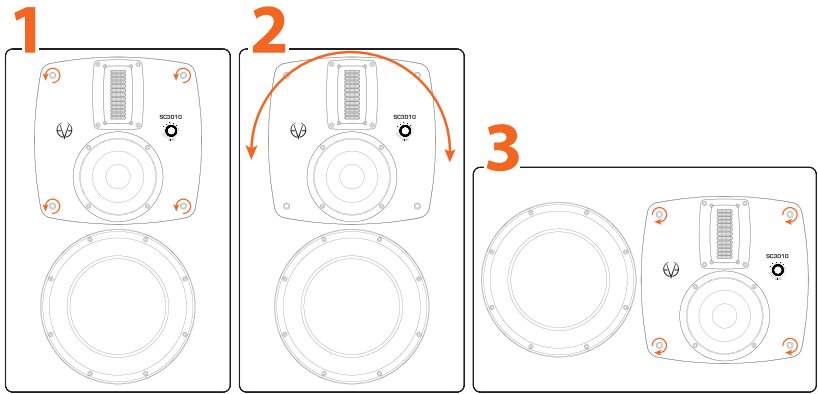

! The whole procedure ought to be carried out with utmost care in order not to damage the surface of the speaker.

### 3.3. Operating Modes

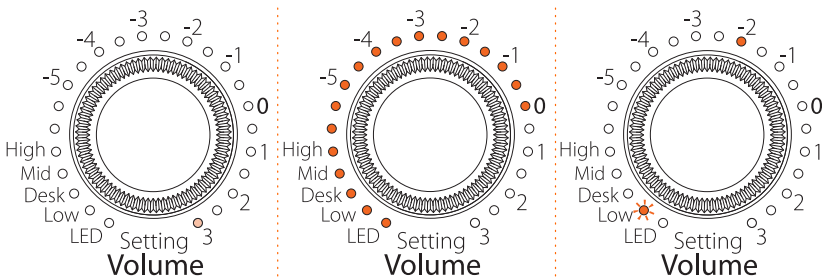

*Standby mode | Volume mode (-10 dB) | Settings menu (Low Filter @ -2 dB)*

### 3.4. Powering on/off: Standby Mode

Press and hold the control three seconds in order to put the monitor in Standby mode. The volume will decrease gradually while the LED ring lights up once around the Volume control. Afterwards, the LED on the right end will remain dimly lit and the power consumption is reduced to 1 watt.

! To exit the Standby mode press briefly the Volume control once again. The level will increase gradually.

### 3.5. Volume Mode

#### Level Adjustment

The maximum input level for balanced (XLR) and unbalanced signals (RCA) is +7 dBu or +22 dBu, depending on the position of the Max. Input switch on the rear panel (see "3.15. DIP Switches" on page 15). Higher levels produce distortion due to the overloading of the analog to digital converter.

Given that some professional studio devices can produce in excess of +22 dBu, the LED ring will start blinking whenever the AD converter is overloading. If that is the case, the output level of the source should be reduced.

#### Volume Adjustment

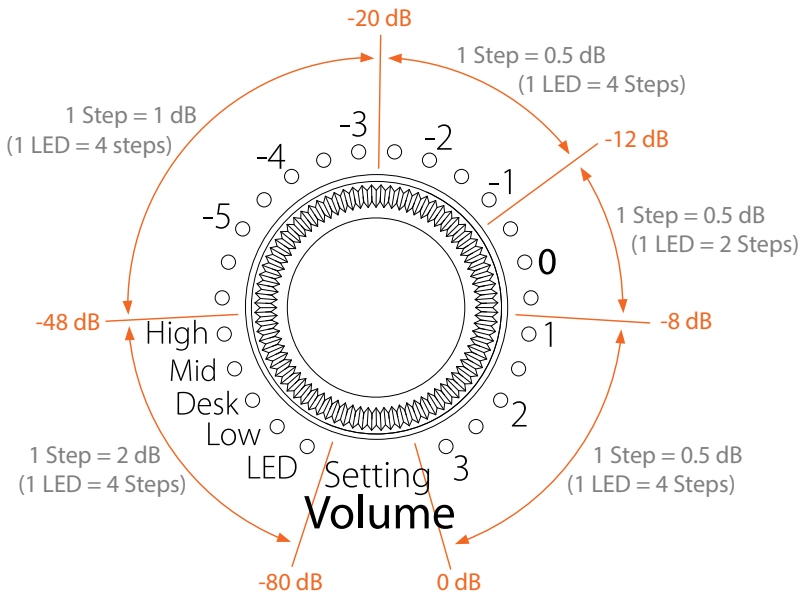

Turn the knob to adjust the volume. Depending on the LED mode selected (see “3.12. LED Mode” on page 14), the volume will be displayed as a dim/bright circle or as a dim/bright point.

The control’s response curve is not linear. The increments become finer as the volume increases:

-80 dB (minimum) to -48 dB:	2 dB
-48 dB to -20 dB:	1 dB
-20 dB to 0 dB (maximum):	0.5 dB

### • **Mute**

To mute the monitor, turn the Volume control counter clockwise until you reach the minimum level. When the LED on the left end lights up dimly the Mute mode is activated.

! To exit the Mute mode simply turn the control clockwise until you reach the desired volume.

## 3.6. **Settings Menu**

Press the control once to enter the Settings menu. Here you can set three different filters (Low, Desk, High), as well as the LED ring’s behavior. The LED of the currently active function will blink.

Turn the control to choose the filter or LED mode desired. The blinking LED indicates the function selected, while the steady-on LED indicates the value assigned to that function.

Press the control to confirm your selection. The blinking will stop once the selection is confirmed.

Turn the control to adjust the filter or the LED behavior.

When you are satisfied with the setting, press the control again to go back to the Settings menu. You can then select and edit another function.

! To exit the Settings menu press and hold the control for three seconds or simply wait 10 seconds. The loudspeaker will then return automatically to the Volume mode.

## 3.7. Filters

The filters of the EVE Audio monitors were specially developed to offer you the possibility of adjusting your monitoring system to the characteristics of your room. These filters help correct the alterations to the frequency response produced by the room acoustics and listening distance. Do bear in mind that correcting bad room acoustics with filters will only achieve average results. In any case, you should try to use the filters as little as possible.

## 3.8. Low Filter

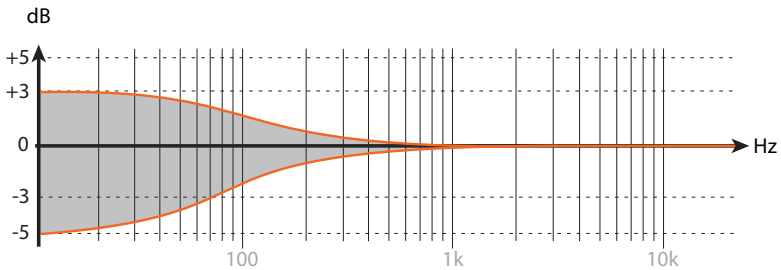

The Low-Shelf Filter allows you to boost or attenuate frequencies below 300 Hz in 0.5 dB steps. Use this filter whenever the acoustics of your room cause problems in the low frequency range.

If the low frequencies are boosted by the room, you can attenuate them with the Low-Shelf Filter. The reasons for this boost could be the room modes or the loudspeakers being too close to the walls. In the same way, if the low frequencies are too weak, you can boost them to balance the frequency response.

## 3.9. High Filter

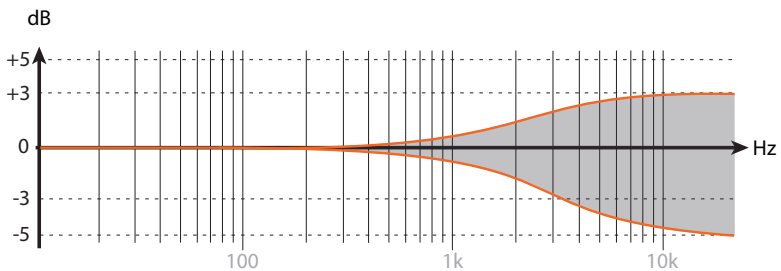

The High-Shelf Filter allows you to boost or attenuate frequencies above

3 kHz in 0.5 dB steps. High frequencies are affected depending on the distance from the sound source to the listening position. The further you are from the loudspeakers, the weaker the high frequencies. In such cases the filter should be set to boost them. In desktop applications, distances can be as short as 1 m (3 ft), which results in the high frequencies being boosted. To compensate for this effect you should use the High-Shelf Filter to attenuate the high frequencies.

If you have a very dead room, it might be wise to boost the high frequencies in order to have a more balanced overall sound. When the listening position is too close to the loudspeakers or the room has reflective surfaces, it is reasonable to attenuate the high frequencies.

### 3.10. Mid Filter

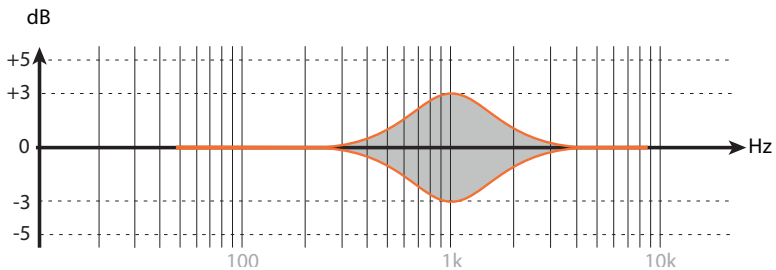

The Mid Filter is a bell filter with 1 kHz center frequency. It allows you to boost or cut the mid range up to +/-3 dB in 0.5 dB steps.

This frequency range is very important for the balance between lower mid and higher mid frequencies. Use the Mid filter to adjust the balance between fundamental and harmonic frequencies in the music material. Depending on the acoustics of your room, some of the sound energy produced by the monitors may be reflected by surfaces like walls, floor and/or ceiling in the room, thus altering the perceived sound.

### 3.11. Desk Filter

The Desk Filter has two functions. When turned down it acts as a narrow-band EQ set to 160 Hz (SC3010 and SC3012).

The reflections of mixers and similar surfaces usually result in the boosting of low mids. With the Desk Filter you can lessen this effect by turning down the filter gain.

When turned up, the Desk Filter also works as an EQ but this time set to 80 Hz. This allows you to give more punch to the lower frequencies.

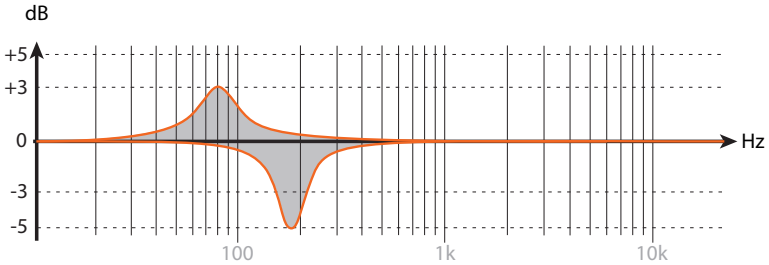

!

The following applies to the Low, High and Desk filters:

- Every step represents a 0.5 dB increment.
- Maximal boost is +3 dB and maximal attenuation is -5 dB.
- Refer to “4. POSITIONING” on page 16 to set the filters of your EVE Audio monitors effectively.

### 3.12. LED Mode

The LED mode determines in which of the four available fashions the LED ring displays the volume level. The LEDs represent given levels, which are displayed and adjusted according to four steps. Intermediate steps are indicated by the brightness between two adjacent LEDs.

•

#### Bright Ring

All LEDs up to the selected volume level light up brightly. The louder the signal, the longer the brightly lit-up ring.

•

#### Bright Point

Only the LEDs corresponding to the selected volume level light up brightly. The louder the signal, the further up the brightly lit-up point moves.

•

#### Dimly Lit Ring

All LEDs up to the selected volume level light up dimly. The louder the signal, the longer the dimly lit-up ring. In this mode, the LEDs light up brightly momentarily while you adjust the volume level.

•

#### Dimly Lit Point

Only the LEDs corresponding to the selected volume level light up dimly. The louder the signal, the further up the dimly lit-up point moves.

!

Intermediate steps are indicated by the lighting of two adjacent LEDs. The level ranges from -60 dB to +10 dB, taking “0 dB” as reference point.

### 3.13. Saving Your Settings

All settings on the front and rear panels are automatically saved. The loudspeakers can be disconnected anytime without the settings being lost.

### 3.14. Power Switch

The power switch on the rear panel disconnects the loudspeaker completely from the power grid. When powered off all settings are saved and the power consumption is reduced to 0 watt.

After powering on again, the loudspeaker will return to the state it was in before being turned off (Standby mode, Mute mode or a given volume level). Even if powered off via a multiple outlet power strip, the monitor will return to the state it was in before being turned off.

! In order to prevent switching noise with your monitoring system, keep in mind the following rules:

Power all audio sources on first and your loudspeakers last.

When turning off your system, power off your loudspeakers first and then all audio sources.

### 3.15. DIP Switches

On the rear panel of your EVE Audio monitors you will find four DIP Switches. Use them to select the input sensitivity and to secure your loudspeaker settings to prevent them from being changed inadvertently.

- **Volume**

When set to “lock,” this DIP Switch secures the current volume setting. The LED ring on the front panel indicates the volume setting, but it cannot be modified. When set to “variable” (var.), the volume setting can be changed by simply turning the knob.

- **Filter**

When set to “lock,” this DIP Switch secures the current filter settings. The filter settings can be read on the LED ring, but they cannot be modified. When set to “variable” (var.), the filters can be modified freely.

- **Not used**

No Function.

- **Max. Input**

This DIP Switch determines the input sensitivity of the SC3010 and SC3012. In a studio environment, the reference level (0 dB) ought to be 4 dBu. In

such environments, leave the setting at “+7 dBu.” However, some studio gear allow much higher output levels. If it were impossible to reduce the output level of such devices, set the switch to “+22 dBu.”

The “+7 dBu” setting ought to be suitable for most situations.

### 3.16. Mains Voltage Selector

The Mains Voltage Selector allows you to adjust the operating voltage of your EVE Audio monitors to the local power grid. Set it to “230” if your local power grid is 220-240 volts or “115” if it is 110-120 volts.

If you change the mains voltage value you also have to replace the fuse of the IEC connector with an appropriate one. The corresponding fuse values are printed on the unit underneath the IEC connector.

### 3.17. Power Connector (IEC)

Use the power cord supplied to connect your EVE Audio monitors to the power grid. The IEC connector includes an integrated fuse. If your EVE Audio monitors stop working and the fuse seems to be the problem, proceed as follows:

- Turn the loudspeaker off.
- Disconnect it from the power grid.
- Detach the IEC connector from the unit.
- Remove the fuse.
- Change the fuse. The replacement fuse should comply with the values stated on the subwoofer.

## 4. POSITIONING

### 4.1. Speaker Positioning + Rubber Feet

Ideally, there should be no objects or obstacles between the loudspeakers and the listening position. Furthermore, a symmetrical positioning is important. This applies to the distance between speakers as well as to the walls, ceiling and floor. In order to have a symmetrical stereo image it is also important to have symmetrical reflections. We recommend to keep a distance of at least 0.5 m (19 inches) to the walls, in order to avoid low frequency boosting.

EVE Audio monitors can also be flush-mounted in a wall, in which case there should be enough air flow. This is important to keep the electronic components cool but also to allow for the best performance of the bass



reflex ports. We recommend to keep at least 3 cm (1 in) to the sides and top.

The SC3010 and SC3012 monitors were designed to be placed vertically or horizontally. The best position in each case will be determined by the room and the system used. By default, your monitor is adjusted to be placed horizontally. To use it in vertical position, turn the tweeter/mid-driver section 90°. Follow the procedure indicated in "3.2. Horizontal/Vertical Orientation" on page 8. Finally, fix the supplied rubber feet to the bottom side of the monitor and place it on an even and stable surface.

**Rubber feet:** your EVE Audio monitors are supplied with four self-adhesive rubber feet. Fix them to the bottom of your loudspeakers to place the monitors safely on an even surface. Furthermore, the rubber feet improve the acoustic decoupling of the loudspeakers from the surface.

### 4.2. Height and Distance

The tweeter of your EVE Audio monitors should be ideally placed at the same height as your ears. If this is not possible tilt the monitors so that the tweeter is directed to your ears.

The ideal distance between the monitors and the listening position is 2-3.5 m (7-11 ft) for both SC3010 and SC3012.

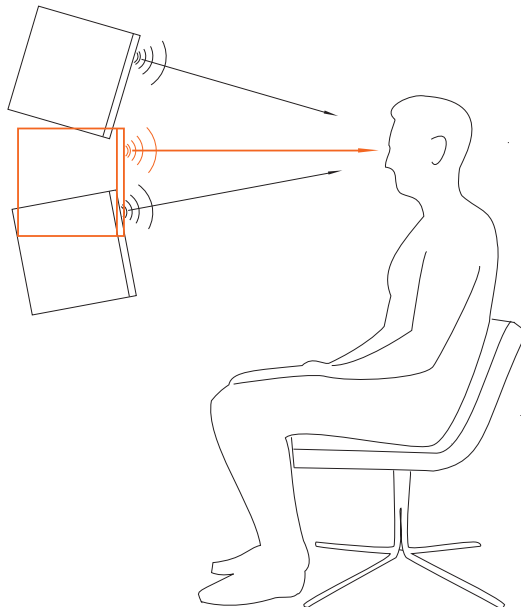

! These values are only meant as a reference and depend a lot on the characteristics of the room. In live rooms you will be forced to reduce the distance, while in dead rooms the distance to the loudspeakers can be larger.

### 4.3. Stereo Setup

The so-called “stereo triangle” is the best way to place speakers in a stereo setup, i.e. the monitors and the listening position should form an equilateral triangle. Try the following:

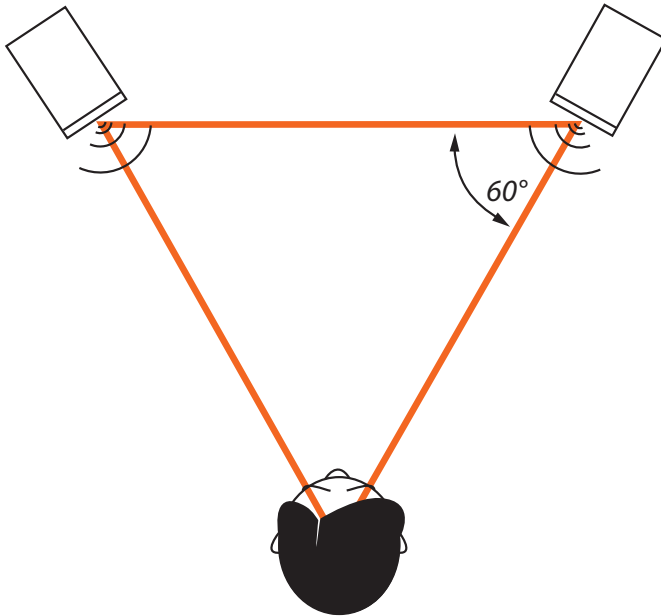

Establish the ideal distance to the listening position (see “4.2. Height and Distance” on page 17).

Place the monitors in such a way that the distance from each other and to the listening position is the same.

Turn both monitors so that their front panels are pointed towards the listening position (all angles of the stereo triangle should be 60°).

### 4.4. Mixer/Workplace Reflections

Regardless of whether the monitors are to be used in a recording studio with a mixing desk and meter bridge or in a desktop environment,

hard surfaces can produce annoying reflections that alter the natural reproduction of the loudspeakers. Especially in the low-mid frequency range.

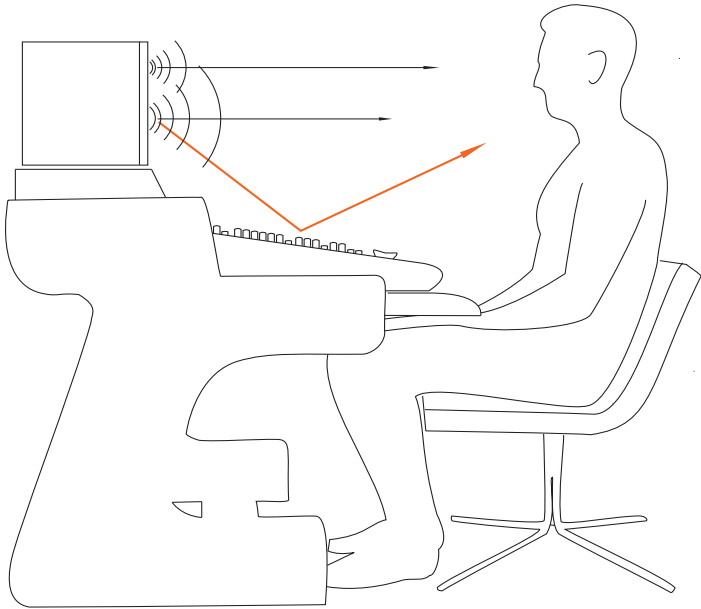

If this is the case with your setup, use the Desk Filter of your EVE Audio monitors to reduce the impact of the reflections from the desk or mixer.

## 4.5. Room Acoustics

In order for the described measures to work effectively, we recommend that you put special attention to the room acoustics. The size, contents, wall parallelism, proportion, and reflective behavior of the room, as well as the corners, the building materials and their characteristics play a very important role in the acoustics of a room.

Room acoustics is a science in itself and it is unfortunately out of the scope of this manual. However, we have put together a short bibliography for you:

- "Recording Studio Design" by Philip Newell. ISBN: 0-240-51917-5
- "Home Recording Studio – Build it like the Pros" by Rod Gervais. ISBN: 1-59863-034-2
- "Studio Akustik" (in German) by Andreas Friesecke. ISBN: 978-3-932275-81-4
- "Praktische Raumakustik" (in German) by Thomas Hentschel. ISBN: 978-3-8364-6800-8
- "Handbuch der Tonstudioteknik" Book 1 (in German) by Michael Dickreiter. ISBN: 3-598-11321-8
- "Handbuch der Audiotechnik" (in German) by Stefan Weinzierl (Ed). ISBN: 978-3-540-34300-4

## 5. TECHNICAL SPECIFICATIONS

Product	SC3010	SC3012
Description	Main Monitor	Main Monitor
Dimensions (WxHxD) (mm)	380 x 580 x 440	435 x 650 x 490
Dimensions (WxHxD) (")	14.96 x 22.83 x 17.32	17.13 x 25.59 x 19.29
Frequency Range (-3dB)	29Hz - 25kHz	25Hz - 25kHz
Tweeter	AMT RS6	AMT RS6
Midrange	130mm/5"	130mm/5"
Woofer	250mm / 10"	300mm / 12"
Crossover Frequencies	240Hz/1,800Hz	220Hz/1,800Hz
Maximum SPL @ 1m	126 dBspl	130 dBspl
Number of Amplifiers	3	3
Output Power (woofer)	800W	800W
Output Power (mid driver)	250W	250W
Output Power (tweeter)	250W	250W
Protection limiter	Yes	Yes
Setting Options		
Volume	-inf. – +6dB	-inf. – +6dB
High-Shelf Filter (-5db – +3dB)	> 3kHz	> 3kHz
Mid Filter (-3db – +3dB)	1kHz	1kHz
Desk Filter Boost (0db – +3dB)	80Hz	80Hz
Desk Filter Cut (-5db – 0dB)	160Hz	160Hz
Low-Shelf Filter (-5db – +3dB)	< 300Hz	< 300Hz
LED brightness setting	Yes	Yes
Volume Lock DIP switch	Yes	Yes
Filter Lock DIP switch	Yes	Yes
Input Level DIP switch	+7dBu / +22dBu	+7dBu / +22dBu
Connections		
XLR Input (impedance)	Yes (10k $\Omega$ )	Yes (10k $\Omega$ )
RCA Input (impedance)	Yes (10k $\Omega$ )	Yes (10k $\Omega$ )
Power Consumption		
Standby	< 1W	< 1W
Maximum	1000VA	1000VA
Miscellaneous		
Weight kg / lb.	37 / 81.6	44 / 97

## 6. COMPLIANCE

We,  
**EVE Audio GmbH**,  
with registered office in  
Ernst Augustin Str. 7, 12489 Berlin, Germany,  
herewith declare that the  
**SC3010 and SC3012**  
comply with the following norms:

**EC Norms:**

EN 60065: 2002 + A1:2006 + A11:2008 + A2:2010 + A12:2011  
EN 50564: 2011  
EN 62301: 2005

**EMC Norms:**

EN 55013: 2013  
EN 55020:2007+A11:2011  
EN 6100-3-2: 2014  
EN 6100-3-3: 2013  
IEC 61000-4-2 ED. 2.0: 2008  
IEC 61000-4-4 ED. 3.0: 2012

This declaration certifies that the quality control and product documentation complies with the current corresponding EU directives.

**Federal Communications Commission interference statement**

This equipment has been tested and found to comply with the limits for a Class B digital device, pursuant to part 15 of the FCC Rules. These limits are designed to provide reasonable protection against harmful interference in a residential installation. This equipment generates, uses and can radiate radio frequency energy and, if not installed and used in accordance with the instructions, may cause harmful interference to radio communications. However, there is no guarantee that interference will not occur in a particular installation. If this equipment does cause harmful interference to radio or television reception, which can be determined by turning the equipment off and on, the user is encouraged to try to correct the interference by one or more of the following measures:

- Reorient or relocate the receiving antenna.
- Increase the separation between the equipment and receiver.
- Connect the equipment into an outlet on a circuit different from that to which the receiver is connected.
- Consult the dealer or an experienced radio/ TV technician for help.

**Caution:**

Any changes or modifications not expressly approved by the grantee of this device could void the user's authority to operate the equipment.

### **Canada, Industry Canada (IC) Notices**

This Class B digital apparatus complies with Canadian ICES-003.

Operation is subject to the following two conditions: (1) this device may not cause interference, and (2) this device must accept any interference, including interference that may cause undesired operation of the device.

### **Canada, avis d'Industry Canada (IC)**

Cet appareil numérique de classe B est conforme aux normes canadiennes ICES-003. Son fonctionnement est soumis aux deux conditions suivantes : (1) cet appareil ne doit pas causer d'interférence et (2) cet appareil doit accepter toute interférence, notamment les interférences qui peuvent affecter son fonctionnement.

Issued in Berlin.

Signature



Roland Stenz  
Managing Director EVE Audio

## 7. WARRANTY

- ▷ The manufacturer warranty is valid for a period of two (2) years after the date of purchase.
- ▷ The warranty covers repair costs (labor and spare parts), product replacement if applicable, and return transport within the country where the product was bought.
- ▷ The warranty will be void if any of the following applies:
  - Damages have been caused by incorrect installation and/or connection,
  - Damages have been caused by misuse or negligence,
  - The unit has been tampered with or modified in any way,
  - The unit has been repaired or modified by unqualified personnel,
  - Damages have been caused by factors beyond the reasonable control of EVE Audio (lightning, fire, flood, etc.)
- ▷ Always keep the original packaging of any EVE Audio product: Only products with original packaging are eligible for warranty service. If the product is not packaged in its original box, EVE Audio will not be liable for any damages occurred during transit.
- ▷ Should service be required during or after the warranty period, please contact your local EVE Audio dealer or distributor.



**EVE AUDIO GmbH**

 Ernst Augustin Str. 7,  
12489 Berlin, Germany

 +49-30-6704 4180

 +49-30-6704 4188

 info@eve-audio.com

 www.eve-audio.com

 facebook.com/EveAudio

 twitter.com/EveAudio